

# **RIVETEC**

*TITGEMEYER Group*

## **Riveting Tool**

**RL 50**

**RL 50A**

**RL 50S**

**RL 50AS**

**Operating Manual**

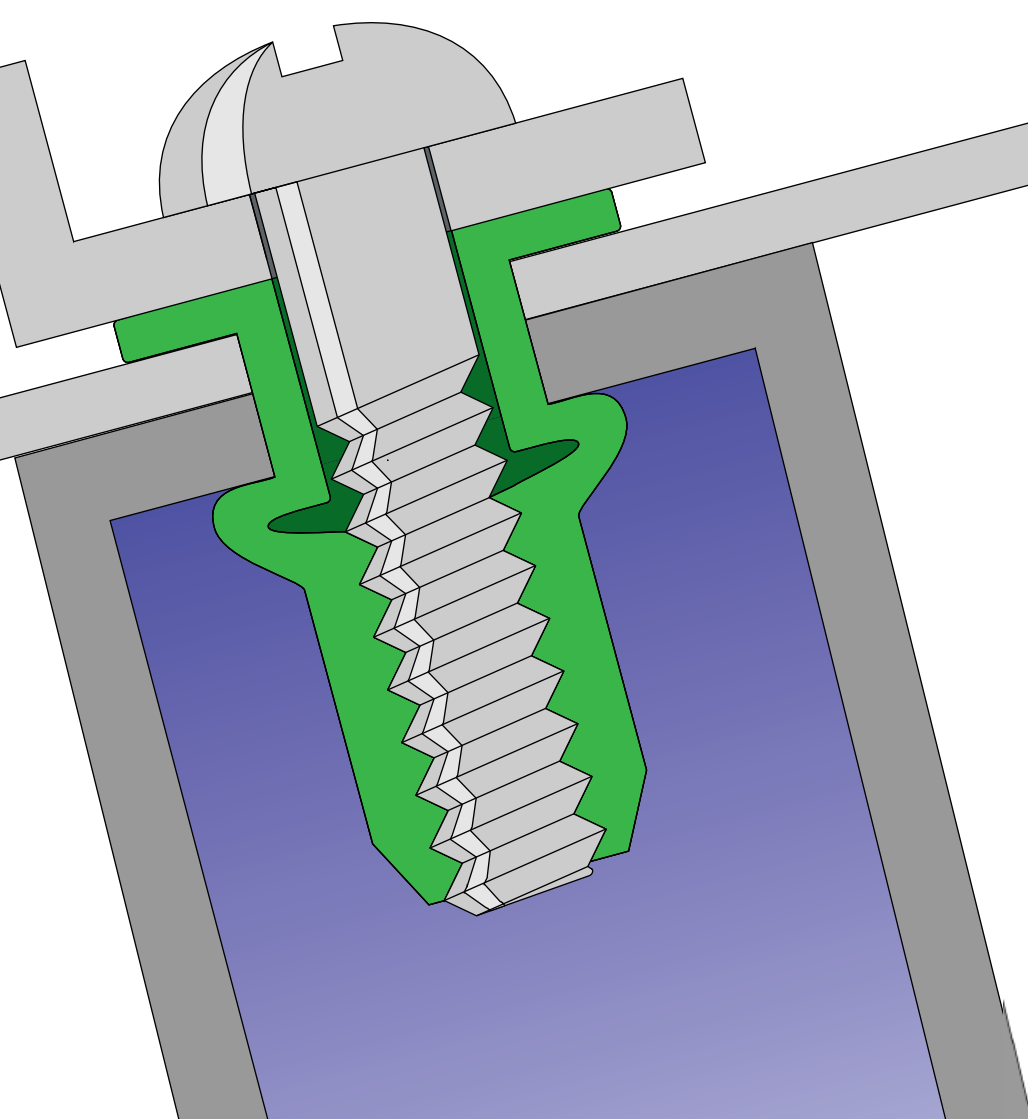

## Table of contents

<b>Guiding instructions.....</b>	<b>4</b>
Cautions, instructions and procedural sections in the operating manual.....	5
Markings on the riveting tool .....	6
<b>Safety instructions .....</b>	<b>7</b>
Basic requirements while dealing with the riveting tool .....	8
Noise and vibration levels of the RL 50/A/S/AS.....	10
<b>Description of the riveting tool .....</b>	<b>11</b>
<b>Required tools.....</b>	<b>13</b>
<b>Storing the riveting tool .....</b>	<b>14</b>
<b>Preparing the riveting tool.....</b>	<b>15</b>
<b>Adjusting the riveting tool .....</b>	<b>17</b>
Changing the mandrel/ internal-thread mandrel.....	17
Adjusting stroke (H) .....	19
Measuring stroke (H) .....	21
Adjusting length L of the mandrel.....	22
Adjusting clearance M of the internal-thread mandrel.....	22
Table stroke adjustment dependent on the grip range .....	23

<b>Operating the riveting tool.....</b>	<b>25</b>
Check function .....	25
Setting blind rivet nut or stud.....	26
Trigger left-handed rotation manually .....	28
<b>Maintaining the riveting tool.....</b>	<b>29</b>
Bleeding the hydraulic section.....	29
Refilling hydraulic oil.....	30
Table for torque values .....	33
<b>Servicing and cleaning the riveting tool .....</b>	<b>34</b>
<b>Maintenance intervals .....</b>	<b>35</b>
<b>Trouble shooting.....</b>	<b>36</b>
<b>Disposal of the riveting tool .....</b>	<b>39</b>
<b>Technical data .....</b>	<b>39</b>
<b>Riveting tool RL50AS .....</b>	<b>40</b>
<b>Guarantee , Package Contents .....</b>	<b>43</b>
<b>Declaration of conformity .....</b>	<b>44</b>

## Guiding instructions

<b>Instruction</b>	The legislator prescribes that the user must be well trained for using compressor-driven riveting tools. On request, this training could be done by dealer or directly by RIVETEC s.r.o.
<b>Technological level</b>	This riveting tool is as per the latest technological standards. For the device to function properly, it is necessary to operate it in an expertly manner, with adherence to safety requirements.
<b>Reading the guiding instructions</b>	Before using the riveting tool for the first time, read the guiding instructions carefully.
<b>Procedures</b>	All the procedures necessary for the operation have been described in these guiding instructions. You may carry out only those procedures, which have been described here.
<b>Obstructions</b>	In case of obstructions, you may repair only those obstructions, which have been marked with an O (Operator).
<b>Illustrations and position-codes</b>	All the illustrations and position-codes in the individual diagrams take reference from the list of parts in the last pages.
<b>Table for torque values</b>	For sizes of screws and threads, you will find a table containing the torque values in the chapter "Maintaining the riveting tool".

## Cautions, instructions and procedural sections in the operating manual

Please follow the instructions and safety informations.

In this operating manual, some sections have been further illustrated through diagrams.

Please acquaint yourself well with these diagrams and their meanings:



**Caution** Hazard of injury! This marking indicates a potential hazard.



**Attention** Material damage! This marking points at a procedure, which may cause damage to the riveting tool or the work-piece.



**Note** This marking indicates useful information

- This point (•) marks every paragraph, which requires you to act by yourself.



**Attention** Environmental hazard! This marking indicates a potential environmental hazard.

### Markings on the riveting tool



This pictogram indicates that you must read the operating manual before using the riveting tool.

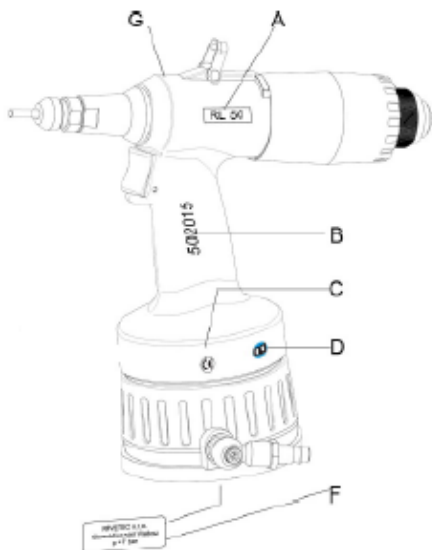

**A** Marking of the type

**B** Serial number

**C** CE-marking

**D** Instruction for reading the operating manual

**F** The value of the maximum operating pressure

**G** Supplier RIVETEC

## Safety instructions

### Application as per the purpose

The riveting tool is exclusively intended for the setting of blind rivet nuts or studs. The riveting tool RL 50/A/S/AS is designed for the processing of blind rivet nuts sizes M3 to M10 (M12/ aluminium) and blind rivet studs size M4 to M8. Upon request mandrels and internal-thread mandrels can also be delivered with other thread dimensions, e.g. UNC/ UNF. This riveting tool must be used only as a hand-held device! The client is fully responsible for any modifications to the riveting tool!

### Improper use

Never throw away or drop the riveting tool!

### Clean and dry compressed air

Please take care that only clean and dry compressed air is let into the riveting tool. Moisture and dirt can damage the riveting tool. Use only such compressed air, which falls into class 2 of air quality as per ISO 8573-1.



**Caution** Hazard of injury because of explosion! Never use the riveting tool in an atmosphere prone to explosions. Ensure that the workplace is well lit and clean. Hazard of injury due to the openly moving compressed air hose. Connect and lay the compressed air hose properly. Hazard of injury due to tripping over! Lay the compressed air hose in such a way that nobody should trip over it.



**Attention** Material damage! The maximum operating pressure is 7 bar. For increasing the durability of the riveting tool, it is recommended to fit a compressed air-maintenance unit in the compressed air hose.

### Basic requirements while dealing with the riveting tool



**Caution** Follow the prevalent guidelines for the prevention of accidents in the respective country.

Use only those fittings and hoses, which have been approved for the operating pressure.

Disconnect the compressed air supply from the riveting tool at the time of installation or maintenance.

Wear personal safety gear (safety glasses and safety helmet).



**Attention** Please read the instructions on the packaging of the blind rivet nuts and studs.

Use the riveting tool only at operating temperatures above 5°C and 45°C.

For different diameters of the rivet shank, use the appropriate nose piece, as prescribed.

Do not throw away the riveting tool.



**Maintenance and servicing** The operator may only carry out the maintenance and repair work described in this operating manual

**Service instructions** Maintenance and service work not described in this operating manual may only be carried out by trained specialists following instruction by RIVETEC on the basis of the service instructions which also exist. See the address on last page for more information on service instructions and training.



**Note** The manufacturer accepts no liability for damage resulting from incorrect repairs or the use of spare parts from other sources.

At the time of leaving the workplace, do not leave the riveting tool with pressure on.

**Guarantee** A guarantee is void, if any repair work carried out on the riveting tool has lead to any damage of the riveting tool.

**Declaration of conformity** The riveting tool RL 50 has been checked and manufactured according to European guidelines. The declaration of conformity can be found on the second last page.

### Noise and vibration levels of the RL 50/A/S/AS

**Noise level** The emission sound pressure level at a workplace is  $L_{PAI} = 86\text{dB(A)}$  according to ISO 10843 and DIN EN ISO 3744.  
The main noise is generated by the air motor. Through correct use, the air motor can be switched off between times, and therefore the noise level can be lastingly reduced.

➔ **Note** For safety reasons, however, we recommend the wearing of ear protection.

**Vibration level** The effective value measured on acceleration with the handle, as per ISO/ FDIS 8662-11, is  $a_{hw} < 2,5\text{m/s}^2$

## Description of the riveting tool

The riveting tool RL 50/A/S/AS is pneumatically - hydraulically actuated and has an air motor

It consists of the following operation-related components:

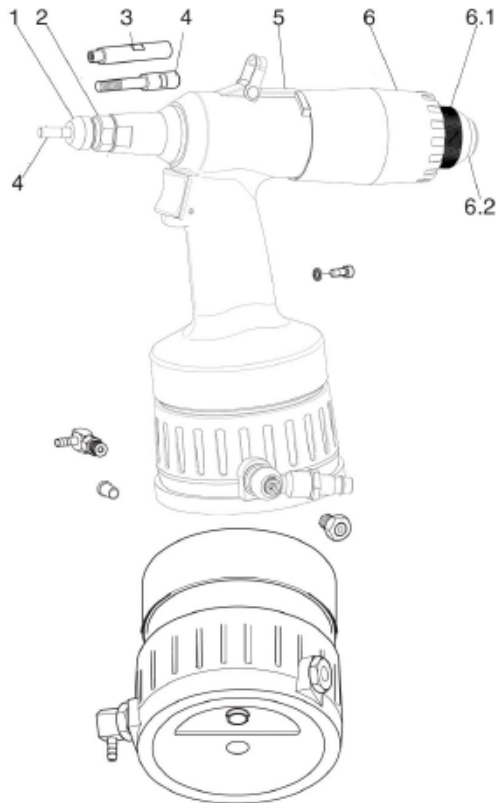

- |            |                         |  |
|------------|-------------------------|--|
| <b>1</b>   | Nose piece              | for threads M3, M4, M5, M6, M8, M10 and M12  |
| <b>2</b>   | Lock nut                | for fixing the nose pieces   |
| <b>3</b>   | Internal-thread-mandrel | for threads M4, M5, M6 and M8 of blind rivet studs   |
| <b>4</b>   | Mandrel                 | for threads M3, M4, M5, M6, M8, M10 and M12 of blind rivet nuts                                    |
| <b>5</b>   | Hydraulic housing       | The pneumatic and the hydraulic units are located in the hydraulic housing                         |
| <b>6</b>   | End cap                 | is a complete unit enabling the switching of the rotation of the air motor to left-handed rotation |
| <b>6.1</b> | Adjustment screw        | is used for adjusting the end stop for the automatic switching to the left-handed rotation         |
| <b>6.2</b> | Button                  | manually release the left-handed rotation  |

## Description of the riveting tool

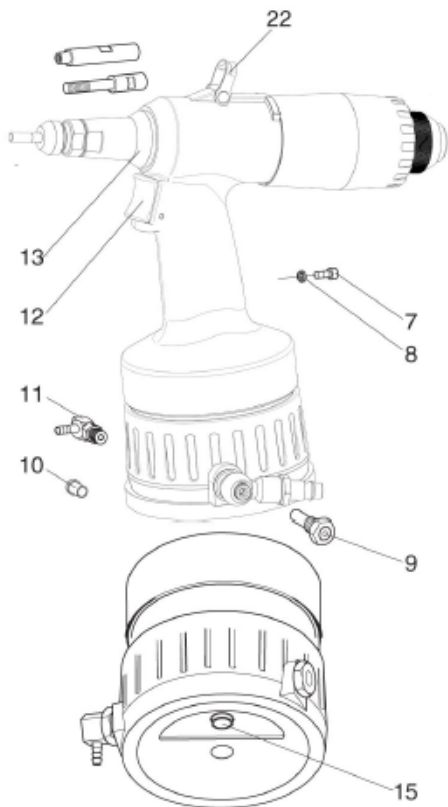

**Note** The socket head screw (7) and the O-ring (8) are screwed tightly into the grip. The socket head screw (7) must not be loosened, else the hydraulic oil will leak.

- |           |                         |   |
|-----------|-------------------------|---|
| <b>7</b>  | Socket head screw       | Locking for the hydraulic oil system<br>Opening serves as an oil inlet                          |
| <b>8</b>  | O-Ring                  | Sealing of the hydraulic oil system   |
| <b>9</b>  | Safety valve            | (Brass) In case of very high pressures (approx. 8 bar or more), it opens, and lets the air out. |
| <b>10</b> | Plug                    | Serves the purpose of protection of the thread and also against dirt                            |
| <b>11</b> | Swivel-joint            | Serves as the connection for compressed air hoses (operating pressure 6 bar)                    |
| <b>12</b> | Trigger                 | — starts right-handed rotation<br>— triggers a riveting action<br>— stops left-handed rotation  |
| <b>13</b> | Nose cap                | covers mandrel and internal-thread mandrel  |
| <b>15</b> | Stroke adjustment screw | is used to adjust the stroke  |
| <b>22</b> | Hang-up eyelet          | For hanging up on a hook whenever stationary  |

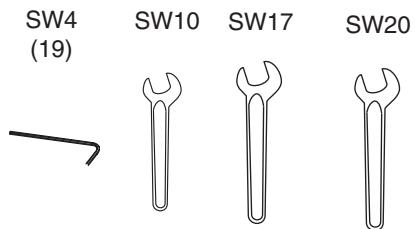

## Required tools

You will require the following tools for all installation, servicing and maintenance work. Keys SW10, SW17 and SW20 which can be ordered by RIVETEC s.r.o.

### Tools

- Wrench<sup>1</sup>
- Internal hex key

2x SW10<sup>1</sup>, SW17<sup>1</sup>, SW20<sup>1</sup>  
SW4 (19)

<sup>1</sup> No delivery possibility

## Storing the riveting tool

### Until first use

If you do not use the riveting tool immediately, store it inside the original packing, dry and dust-free.

### Long term storage after usage

Clean nose piece (1), lock nut (2), internal-thread mandrel (3) and/ or thread mandrel (4) and grease with con-corrosive grease. Screw out the swivel joint (11) and close the opening with a plug (10). If possible, store all pieces in the original packing.

### After long-term storage

After long-term storage (about 3 years), change the hydraulic oil before re-use.

A hydraulic oil change may only be carried out by trained specialist with the help of the service instructions. For further information regarding service instructions and training, please see the address on page 42.

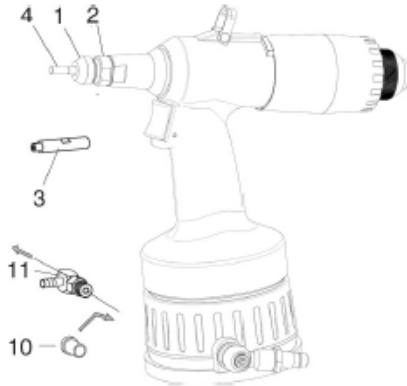

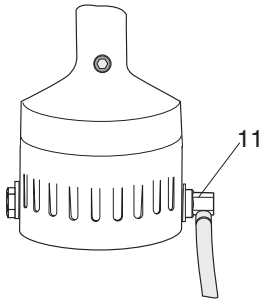
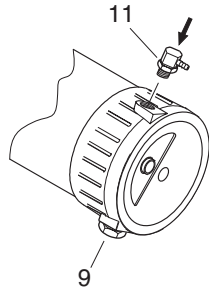
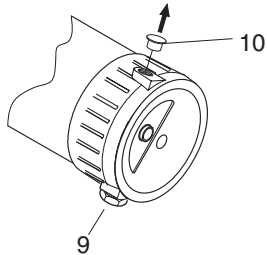

## Preparing the riveting tool

### Package insert

The components ordered by you are marked as per the checklist found inside the packing.



**Note** Please check the contents of the packing, for completeness of the checklist

In every case, please carry out a visual check of the riveting tool before starting any work:

- for external damages,
- for oil leakage from the riveting tool.

- Remove the plug (10) from the connection port, and store in the original packing.



**Note** The swivel joint (11) and the safety valve (9) can be alternatively fitted on both the sides of the hydraulic housing. The diagram below shows the arrangement for a right-hander



**Note** In case of all screw-fittings, observe the table for torque values in the chapter "Maintaining the riveting tool"

- Screw on the swivel joint (11) and tighten using the wrench SW17 (see "Table for torque values").

## Preparing the riveting tool

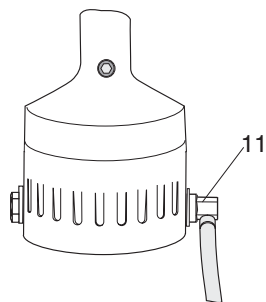

### Note

Depending on the type of compressed air supply, it may be necessary to connect a fitting different from the one provided, to the riveting tool. For this, you need to have a fitting having a 1/4" Withworth-pipe-thread as per ISO 228.



### Caution

Danger of injury by running riveting tool. In this event, lightly touch the trigger to stop the riveting tool.



### Attention

Material damage by compressed air!  
As per norm ISO 8573-1, class 2, compressed air must be dry and clean. We recommend that you fit a compressed air-maintenance unit to the riveting tool.

- Compressed air hose should be connected to the swivel joint (11), as prescribed.



### Attention

Too narrow clearance can cause damage to material. If you do not know the stroke setting, unscrew the adjustment screw (6.1) for the automatic switching into the left/ handed rotation a few turns (ca. 5 mm). This is to ensure that the piston will not hit the back and the riveting tool will not be damaged.

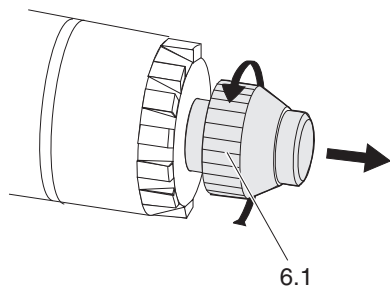

### Note

The operating pressure must be between a minimum of 5 and a maximum of 7 bar!



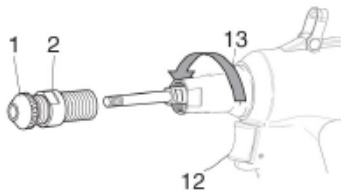
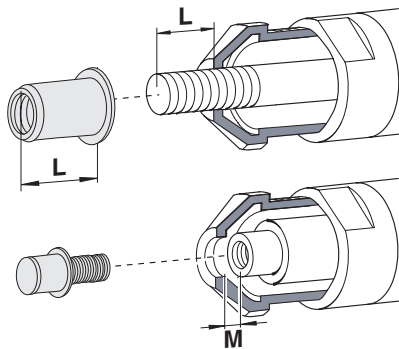
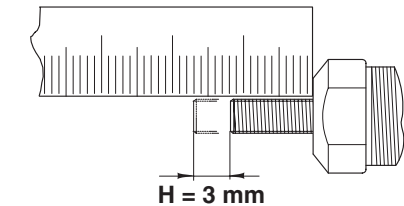

## Adjusting the riveting tool



**Note** The working stroke (H) is set at 3 mm. Adjust the riveting tool to your conditions and change the mandrel/ internal-thread mandrel correspondingly

## Changing the mandrel/ internal-thread mandrel



**Caution** Risk of injury by crushing and shearing due to an accidental working stroke! Always disconnect the compressed air supply before unscrewing the nose cap.



**Attention** Material damage! Every time you change the mandrel/ internal-thread mandrel you must readjust the length L (mandrel), the clearance M (internal-thread mandrel) and the working stroke (H). In addition to this, the adjustment screw for the automatic switch over into left-handed rotation (6.1) needs to be adjusted to the new stroke.

- Select and grease corresponding mandrel/ internal-thread mandrel
- Unscrew lock nut (2) with open wrench SW20.
- Unscrew nose piece (1).



**Attention** Use box wrench SW20 (18) for nose cap (13). Trigger (12) can be damaged if an open wrench slips!

- Loosen and unscrew nose cap (13) with box wrench SW20 (18).

## Adjusting the riveting tool

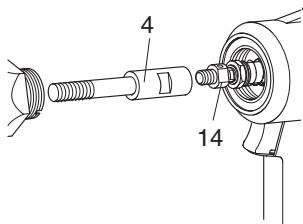
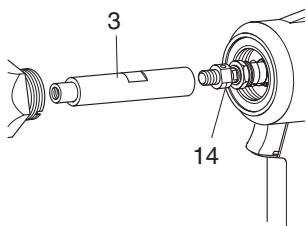

- Position open wrench SW10 on the mandrel (4)/ internal-thread mandrel (3).
- Pushing against the lock nut (14), loosen and unscrew the mandrel/ internal-thread mandrel.



**Note** Grease the new mandrel/ internal-thread mandrel lightly with non-corrosive grease. Follow the table for tightening torques in the Chapter "Maintaining the riveting tool".

- Screw in new mandrel/ internal-thread mandrel (min. 6 turns) and tighten them against pressure on the lock nut (14) (see page 33 "Table for torque values").



**Attention** Use box wrench SW20 (18) for nose cap (13). Trigger (12) can be damaged if an open wrench slips!

- Screw in nose cap (13) and tighten firmly with box wrench SW20 (18) (see page 33 "Table for torque values").
- Screw in appropriate nose piece.



**Note** You must first adjust the stroke. Then you must adjust the length L of the mandrel and the clearance M of the internal-thread mandrel (consult the photo on page 17).

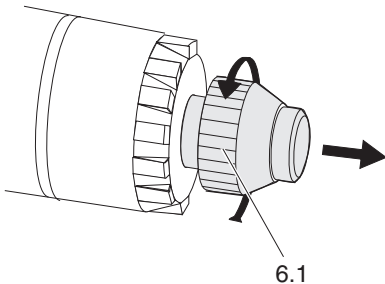
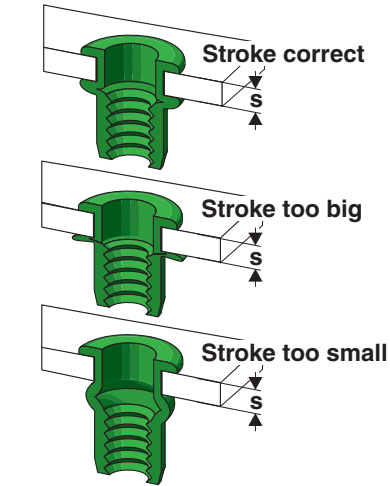

## Adjusting stroke (H)



**Note** The correct stroke (H) depends on the kind of blind rivet nut or stud, on the thread size and on the thickness of the material (s). You will find standard values for the stroke in the table "Stroke Adjustment Dependent on Grip Range" on page 23-24. The given values in the table are valid for blind rivet nuts and studs manufactured by RIVETEC. If you use blind rivet nuts or studs from another manufacturer, please find out the values from the manufacturer when you do not have the relevant information or instructions.

If the strength of the material deviates from the values, you must adjust the stroke (H) accordingly:

- thinner material requires a larger stroke,
- thicker material requires a smaller stroke.



**Attention** Material damage! If you do not know the stroke setting, unscrew the adjustment screw (6.1) a few turns (ca. 5 mm) for the automatic switch over to the left-handed rotation. This is to ensure that the piston will not hit the back and the riveting tool will not be damaged.



**Attention** Material damage! Perform a sample riveting after every adjustment and test the deformation of the blind rivet nut or stud. In the above picture you can see the correct setting of a riveting, taking a blind rivet nut as an example.

## Adjusting the riveting tool

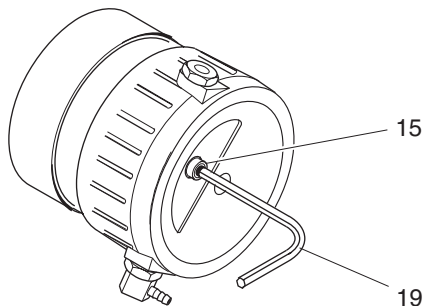

The adjustment to another working stroke follows on the underside of the riveting tool. For this you need the spanner for internal hex key SW4 (19).



**Note** If the stroke adjustment screw (15) is turned out by counter-clockwise rotation up to the end-stop, the stroke is approximately 5.7 mm.

- Check if the compressed air hose is connected. If not, connect the compressed air supply.

Using the spanner for hexagon nuts turn the stroke adjustment screw in the relevant direction:

- right “-” reduce the stroke
- left “+” increase the stroke



**Note** Four turns of the stroke adjustment screw correspond to a stroke adjustment of 1 mm.



**Attention** Material damage! If you do not know the stroke setting, unscrew the adjustment screw (6.1) a few turns (ca. 5 mm) for the automatic switch over to the left-handed rotation. This is to ensure that the piston will not hit the back and the riveting tool will not be damaged.

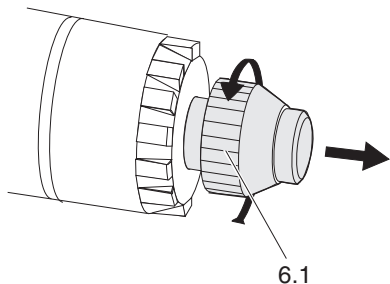

You must now measure the stroke (H) (see page 21).

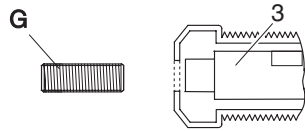

## Measuring stroke (H)

**Note** When using an internal-thread mandrel (3), you must first screw in a grub screw of the corresponding size.



**Attention** Material damage! If you do not know the stroke setting, unscrew the adjustment screw (6.1) a few turns (ca. 5 mm) for the automatic switch over to the left-handed rotation. This is to ensure that the piston will not hit the back and the riveting tool will not be damaged.

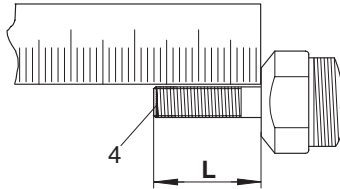

- Establish an air supply (max. 7 bar).
- Measure the projecting length L of the mandrel (4) or grub screw (G)
- Press the trigger (12) right through and hold.
- Measure the remaining length B of the mandrel (4) or grub screw.
- Release the trigger (12).

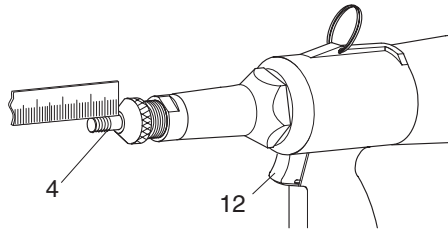

**Length L minus length B gives the actual stroke H ( $L-B=H$ ).**

- If necessary correct the stroke (H) (see adjustment of stroke H on page 19).
- Adjust the adjustment screw (6.1).

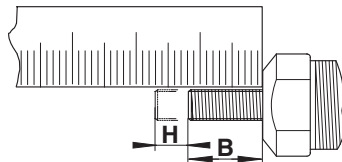

**Attention** Material damage! Always readjust the nose piece after every stroke adjustment. Perform a sample riveting to check if sound riveting is possible.



**Note** Check the stroke adjustment every 300 rivetings or after 25 operating hours.

## Adjusting the riveting tool

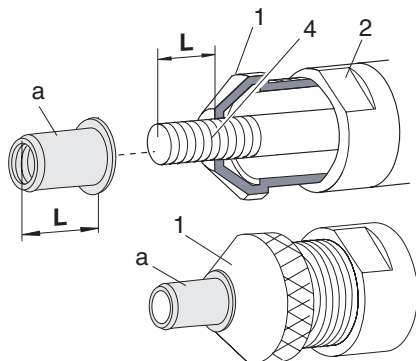

### Adjusting length L of the mandrel



**Note** The mandrel (4) must cover the whole length L of the blind rivet nut (a). The head of the blind rivet nut must be adjacent to the nose piece (1).

- Loosen the lock nut (2) with the open wrench SW20.
- Unscrew the blind rivet nut (a) so that the whole length of the blind rivet nut is exposed.
- Turn the nose piece (1), so that the head of the blind rivet nut (a) lies adjacent to the nose piece.
- Firmly tighten the lock nut (2) (see page 33 "Table for torque values").

### Adjusting clearance M of the internal-thread mandrel

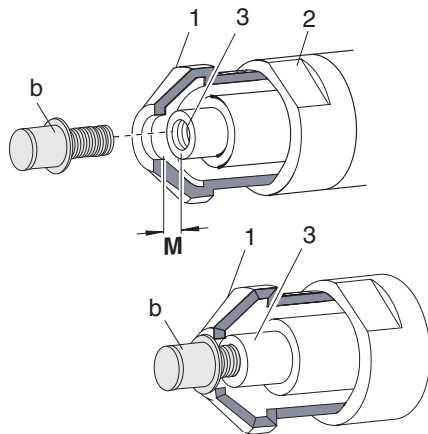

**Attention** Material damage! The internal-thread mandrel must not touch the inside of the nose piece. A gap of  $M = \text{approx. } 1 \text{ mm}$  must be retained.

- Unscrew the nose piece (1) so that it lies adjacent to the internal-thread mandrel (3).
- Gently tighten the lock nut (2).
- Then unscrew the nose piece one turn.
- Firmly tighten the lock nut (2) with the open wrench SW20 (see page 33 "Table for torque values").

**Table stroke adjustment dependent on the grip range**

Type	Grip range (mm)	Aluminium Stroke (mm)	Steel Stroke (mm)	Special Steel Stroke (mm)
M3	1,0 2,0	2,0 1,5	2,5 2,0	—
	2,0 3,0	1,5 1,5	2,5 2,0	—
M4	1,0 2,0	—	—	2,0 1,5
	1,0 3,0	3,0 1,5	2,5 1,5	—
	2,0 3,5	—	—	2,5 2,0
	3,0 4,5	2,5 1,5	2,5 1,5	—
M5	1,0 3,0	3,5 2,0	3,5 2,5	2,5 2,0
	3,0 5,5	3,5 1,5	4,0 2,0	—
M6	1,0 3,0	3,0 2,0	4,0 3,0	4,0 3,0
	3,0 5,5	3,5 2,0	3,5 2,0	—
	5,5 8,0	4,5 2,0	4,0 2,5	—

In this table you will find the standard values for blind rivet nuts and studs manufactured by RIVETEC, in order to help you to preselect the stroke on the riveting tool.

When using the blind rivet nuts and studs of other manufacturers, you will require the corresponding values.

## Adjusting the riveting tool

Type	Grip range (mm)	Aluminium Stroke (mm)	Steel Stroke (mm)	Special Steel Stroke (mm)
M8	1,0 3,0	3,0 2,0	4,0 2,5	4,0 2,5
	3,0 5,5	4,0 2,0	4,0 2,5	—
	5,5 8,0	4,0 2,0	4,0 2,5	—
M10	1,0 3,0	—	—	3,5 2,5
	1,0 3,5	4,0 2,5	4,5 2,5	—
	3,5 6,0	5,0 3,0	4,0 2,5	—
	1,0 3,5	—	4,5 2,5	—
	3,5 6,0	—	5,5 3,0	—
M12	1,0 4,0	—	5,5 4,0	—
	4,0 7,0	—	5,5 4,0	—



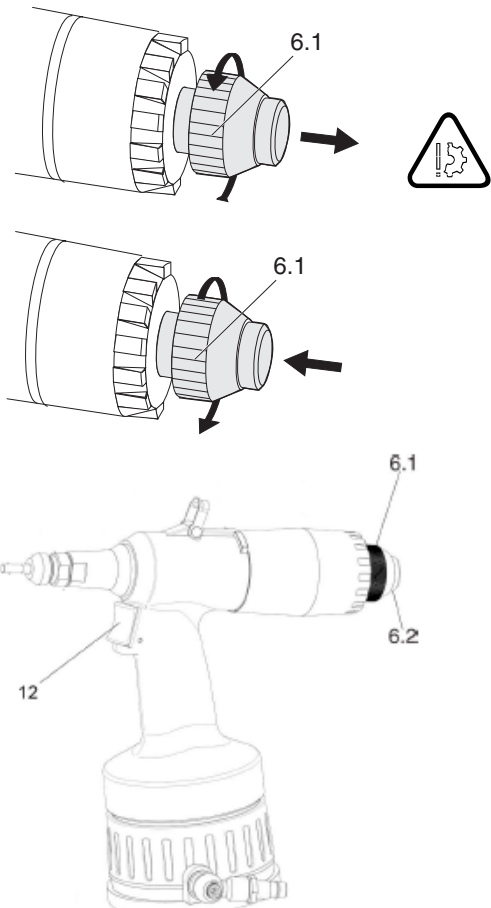

## Operating the riveting tool

### Check function



**Attention** Material damage! If you do not know the stroke setting, unscrew the adjustment screw (6.1) a few turns (ca. 5 mm) for the automatic switch over to the left-handed rotation. This is to ensure that the piston will not hit the back and the riveting tool will not be damaged.

- Connect the air supply to the riveting tool.
- Push the trigger (12) through and hold.
- Gently screw in the adjustment screw (6.1) as far as it can go: The automatic switch over to left-handed rotation is now set.
- Release the trigger (12).
- Gently push down the trigger (first level): The air motor is rotating in a right-handed direction.
- Release the trigger (12): the air motor stops.
- Again press the trigger down to the first level: The air motor rotates in a right-handed direction.
- Push the trigger (12) right through and hold (second level): the mandrel or internal-thread mandrel is pulled backwards; the air motor stops.
- Release the trigger (12): the air motor rotates to the left; the mandrel or internal-thread mandrel goes to the front.
- Gently tap the trigger (12): The air motor stops.
- Push button (6.2): The air motor rotates towards the left.
- Gently tap the trigger (12): The air motor stops.

## Operating the riveting tool

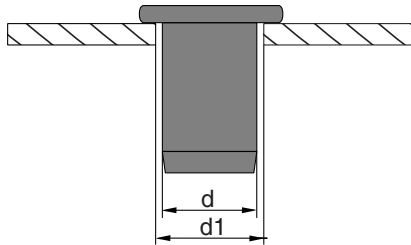
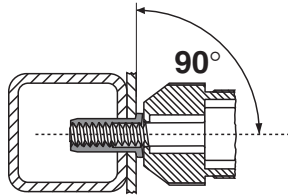

### Setting blind rivet nut or stud



**Attention** Material damage! Under no circumstances should you rivet (rerivet) blind rivet nuts and studs. This could damage the riveting tool and the work piece.



**Attention** Material damage! Always position the riveting tool at right angles (90°) on the work piece to be riveted. A more slanted fit leads to a faulty rivet or damage to the mandrel or internal-thread mandrel.



**Note** Use bore size ( $\varnothing d1$ ) in the catalogue information of the manufacturer or calculate it according to the following formula:

$$\varnothing d1 = \varnothing d + (0,1-0,2)\text{mm}$$



**Attention** Material damage! If the diameter of the bore is too large or if the bore is oval, faulty rivetings will result.

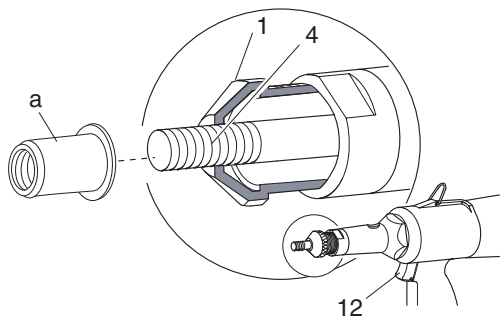

**Note** Grease the thread (mandrel (4) and blind rivet stud (b)) with non-corrosive oil, so that the blind rivet nut or stud is easily screwed and unscrewed.

- Position the blind rivet nut (a) or stud (b) on the mandrel (4) or internal-thread mandrel (3).
- Gently press the trigger (12) down and hold (first level): the blind rivet nut or stud is automatically unscrewed by the right-handed rotation of the air motor.



**Note** The right-handed rotation stops automatically when the head of the blind rivet nut (a) or stud (b) is positioned on the nose piece.

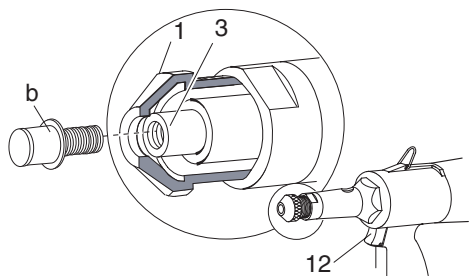

- Insert the unscrewed blind rivet nut (a) or stud (b) in the prepared bore (no photo).
- Push the trigger (12) through as far as possible and hold; this will secure the rivet shank.
- Release the trigger (12): the appliance automatically switches the left-handed rotation; the mandrel is unscrewed from the blind rivet nut and the internal-thread mandrel is unscrewed from the blind nut or stud.
- Tap the trigger (12): the left-handed rotation stops.

## Operating the riveting tool

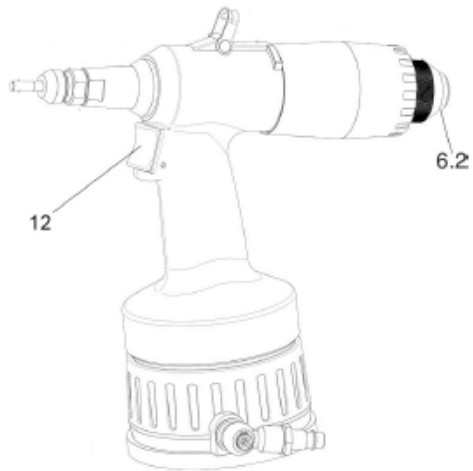

### Trigger left-handed rotation manually

- Connect the air supply.
- Push the button (6.2):  
The air motor rotates in the left-handed direction.
- Quickly touch the trigger (12):  
The air motor stops.

## Maintaining the riveting tool



**Caution** Hazard of injury if handled in an improper manner! Servicing, maintenance and repairs of the riveting tools must be carried out professionally. On completing this work, there should not be any more hazard to the operator, if used as per the regulations. The operator may only carry out the operations mentioned here.

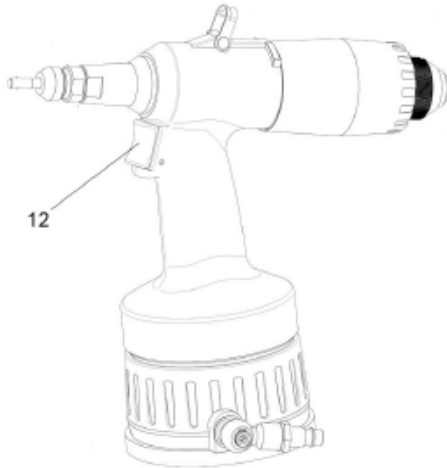

### Bleeding the hydraulic section

It is necessary to bleed the hydraulic section or to refill the hydraulic oil when:

- oil is leaking from defective O-rings,
- after an oil-change at the time of an overhaul (either after a maximum of 3 years, or after 2000 working hours).



**Achtung** Immediately replace defective sealings. Maintenance and service work not described in this operating manual may only be carried out by trained specialists following instruction by RIVETEC on the basis of the service instructions which also exist. See the address on page 42 for more information on service instructions and training.

- Detach the compressed air connection.
- Tap trigger (12): You will bleed the inside of the compressed air systems; pistons are in a neutral position.

## Maintaining the riveting tool

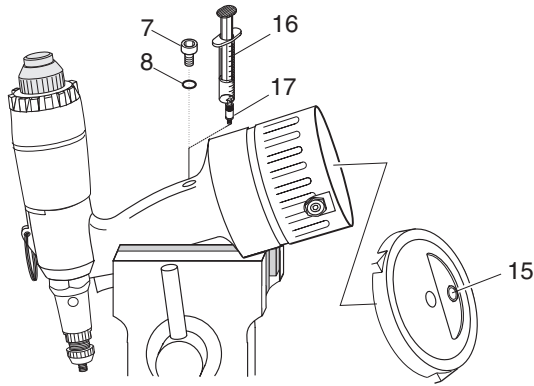

### Refilling hydraulic oil

- ➔ **Note** Before you fill up the hydraulic oil you must bleed the hydraulic section (see "Bleeding the hydraulic section" on page 29).
- ➔ **Note** If you clamp the riveting tool into a vice, then insert a soft material in-between (Alu/ wood).

- Tilt the riveting tool forwards and secure it, e.g. in a vice (see photo).

This position is critical, where the trapped air can escape when necessary (bleeding the hydraulic section).

- Set the working stroke to the maximum stroke: Unscrew stroke adjustment screw (15) with the spanner for internal hex key SW4 (19) in the direction + as far as possible.

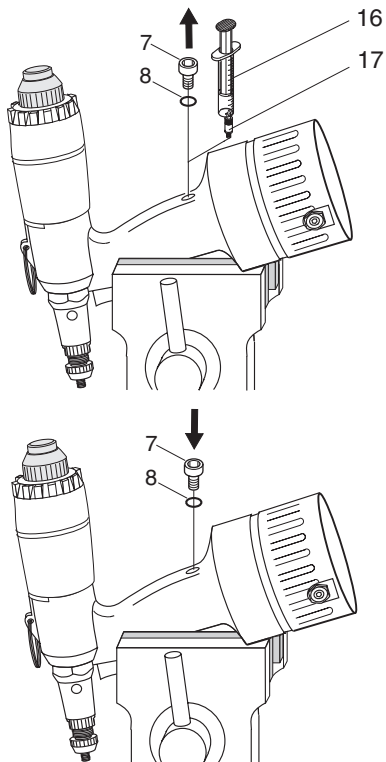

**Attention** Environmental hazard! Always use a large bowl for collecting oil. Please observe all the environmental regulations prevalent in the respective area.



**Attention** Material damage! Do not let the O-ring (8) be damaged. If the O-ring gets damaged, then replace immediately.

- Unscrew the socket head screw (7) in the hydraulic housing carefully, using the internal hex key SW4 (19).
- Screw the oil refill adapter screw (17) into the free opening.
- Set the filled oil gun (16).
- Using the oil gun (16), inject the hydraulic oil (e.g. DEA Astron HLP 32 or a similar grade oil) firmly.
- Withdraw the oil gun (16) and unscrew the oil refill adapter screw (17).
- Screw on the socket head screw (7) with O-ring (8) and tighten using an internal hex key SW4 (19) (see page 33 "Table for torque values").
- Rub the riveting tool dry.

## Maintaining the riveting tool

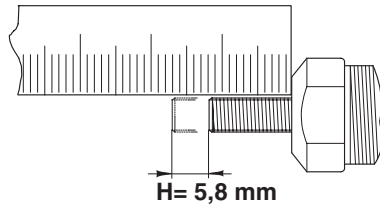
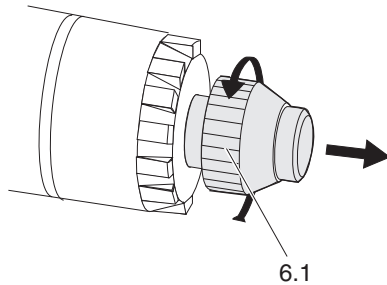

**Attention** Material damage! If you do not know the stroke setting, unscrew the adjustment screw (6.1) a few turns (ca. 5 mm) for the automatic switch over to the left-handed rotation. This is to ensure that the piston will not hit the back and the riveting tool will not be damaged.



**Note** The maximum working stroke may only vary between  $\pm 0,2$  mm. If the maximum working stroke is too narrow, you must fill up the hydraulic oil.

- Reconnect the air supply.
- Perform the operation without the blind rivet nut or stud. The maximum working stroke (ca. 5,8 mm) must be available.
- Readjust the adjustment screw 6.1 for the automatic switch over to left-handed rotation ( see "Operating the riveting tool" on page 25).



## Table for torque values

In the following table, you will find torque values, which you are required to adhere to while tightening the screws/ nuts.

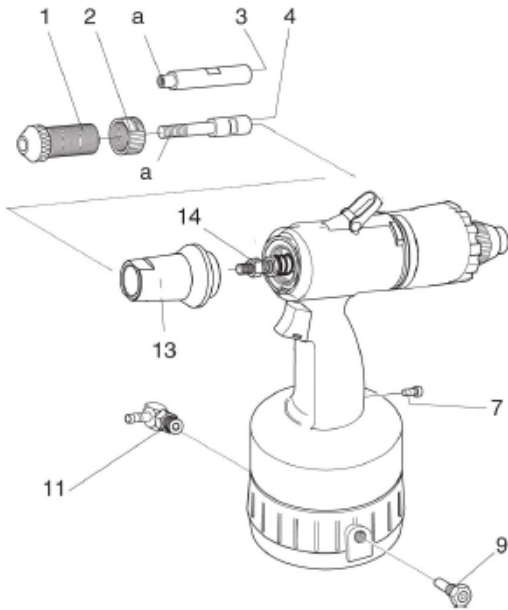

Pos.	Name	Threading	Torque value MA in Nm
1	Nose piece	Metrical M18x1	10
2	Lock nut	Metrical M18x1	10
3	Internal-thread mandrel	Metrical M8	7
4	Mandrel	Metrical M8	7
7	Socket head screw	Metrical M6	4
9	Safety valve	Withworth-pipe-thread 1/4"	20
11	Swivel joint	Withworth-pipe-thread 1/4"	20
13	Nose cap	Metrical M26x1,5	20
14	Lock nut	Metrical M8	7

a= thread without instructions for a tightening torque.

## Servicing and cleaning the riveting tool



**Caution** Hazard of injury if handled in an improper manner! On completing this work, there should not be any more hazard to the operator, if used as per the regulations. The operator may only carry out the operations mentioned here. Maintenance and service work not described in this operating manual may only be carried out by trained specialists following instruction by RIVETEC on the basis of the service instructions which also exist. See the address on last page for more information on service instructions and training.

Hazard of injury if the riveting tool falls down! The hydraulic housing must always be kept dry, clean and oil- and fat-free.



**Attention** Material damage due to corrosion! Do not use any highly active cleaning agents or combustible liquids for cleaning purpose!

The following routine is recommended:

Grease the mandrels with a drop of non-corrosive oil at regular intervals (see page 35 "Maintenance Intervals").

The riveting tool must be cleaned and checked for mechanical defects as per the respective application type.

After the riveting tool has been cleaned and when it is to be stored for a longer period of time, lightly grease all metal outside components with non-corrosive grease.

## Maintenance Intervals

Intervall	Activity	How?	Who?	Remark
Daily before use	Check for cracks	Visual check	Operator	—
Daily before use	Check the riveting tool for wear	Visual check/ Functional check	Operator	Only specialists should change the worn parts
Daily before use	Check the air discharged from the tool	Visual check, Remove dirt	Operator	Air may only be directly released through the engine and the valve in the floor plate
Daily before use	Check for oil leaks from the riveting tool	Visual check, if necessary refill the oil, bleed the hydraulic system	Operator	—
Daily after use	Oil the threads of the mandrels/ internal-thread mandrels	Grease the thread with a drop of non-corrosive oil	Operator	—
Daily after use	Clean riveting tool	With a rag	Operator	—
Daily after use	Oil moving parts (not Trigger (12))	With acid-free oil e.g. ELFOLNA 46	Operator	—
Every 300 rivetings/ 25 operating hours	Check the stroke setting	Measuring stroke (H)	Operator	Readjust the nose piece after every stroke adjustment
Every 5-10 000 rivetings / 500 operating hours	Change the hydraulic oil	With acid-free oil e.g. DEA Astron HLP 32	Professional	Oil changes should only be carried out by specialists

## Trouble shooting

Operations, which may be carried out by the operator, are marked with the letter **O**.

Operations, which may be carried out only by an expert person, are marked with the letter **P**.



**Caution** Hazard of injury! In any case, keep the compressed air supply detached till the source of the problem is eliminated.



**Attention** Material damage! The work marked by the letter **O** should only be carried out by trained specialists with the aid of the service instructions. Alternatively the tool should be sent for overhauling.

Any replacement of original spare parts may be carried out only by well-trained experts.



**Note** After every instance of problem-removal, a thorough functional check must be carried out.

Problems	Cause	Solution
Blind rivet nut or stud was not rived and/ or not correctly riveted	<p>Supply of compressed air is too rare</p> <p>Stroke (H) is not correct</p> <p>Oil deficiency</p>	<p>(O) Check compressed air supply</p> <p>(O) Set the air at the maintenance level of 6 bar</p> <p>(P) If the operating pressure is o.k., send the riveting tool for overhauling</p> <p>(O) Readjust Stroke (H) (see page 19)</p> <p>(O) Fill up the oil (see page 29)</p>
Safety valve gets blown off	<p>Compressed air pressure is too high</p> <p>Valve is defective</p>	<p>(O) Check and adjust compressed air setting</p> <p>(O) Replace safety valve</p>
Excessive loss of oil from riveting tool	Leaking and worn joints	(P) Have trained specialists repair the riveting tool or send it for overhauling
Air bubbles in the hydraulic system	<p>O-ring is leaking</p> <p>Not correctly vented/ bled</p>	(O) Bleed the hydraulic section (see page 29 "Maintaining the riveting tool")
Loss of hydraulic oil due to leakage	Defective O-rings in the riveting tool	<p>(O) Detect leakage</p> <p>(O) Change O-ring (8)</p> <p>(O) Send the riveting tool for overhauling</p>

## Trouble shooting

Problems	Cause	Solution
Air motor does not rotate to the left.	<p>Supply of compressed air is too rare</p> <p>Falsely adjusted adjustment screw (6.1)</p> <p>Oil deficiency</p>	<p>(O) Check the air supply</p> <p>(O) Set the air at the maintenance level of a maximum of 7 bar</p> <p>(O) Readjust the adjustment screw (6.1)</p> <p>(O) Refill the oil (see page 19)</p>
Air motor does not rotate to the right	<p>Supply of compressed air is too rare</p> <p>Worn valve screw fitting or gasket is defect</p> <p>Unclean air, pollution of the air flow in the valve slide</p>	<p>(O) Check the air supply</p> <p>(O) Set the air at the maintenance level of a maximum of 7 bar</p> <p>(P) Test the parts and change them if necessary, or send the riveting tool to be overhauled.</p> <p>(P) Remove the valve slide and clean or send the riveting tool for overhauling</p>

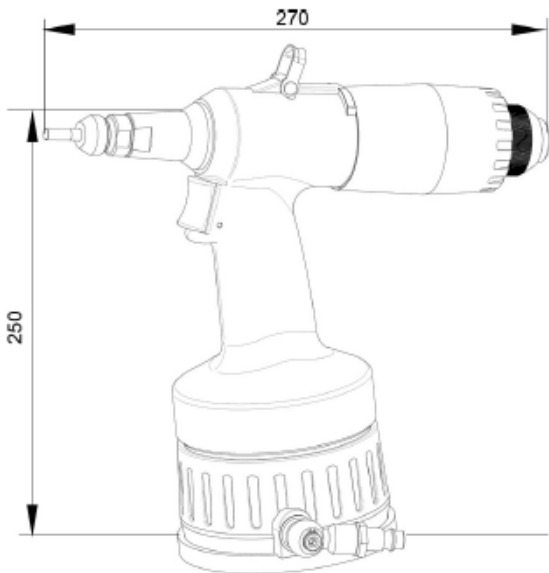

## Disposing of the riveting tool

Ensure that the hydraulic oil is inside the riveting tool. Dispose it off in an environmentally friendly manner.

Send the riveting tool back to the manufacturer in it's original packing, if still available.

## Technical data

Type of riveting tool:	RL 50
Height:	250 mm
Width:	270 mm
Weight:	2,2 kg
Operating pressure:	6 bar
Compressed air supply	
Nominal diameter:	DN 6
Power output (at 6 bar):	ca. 23,5 kN
Operating stroke:	ca. 1,5...5,8 mm
Air consumption per riveting:	0,28 l
Engine air consumption:	23,3 l/min.
Field of work	
Blind rivet nuts:	M3...M10(M12/ Alu)
Blind rivet studs:	M4...M8
Sound emission level in the workplace:	$L_{PAI}=86dB(A)$
Vibration level:	$a_{hw}<2,5m/s^2$ .

# Riveting tool RL50AS

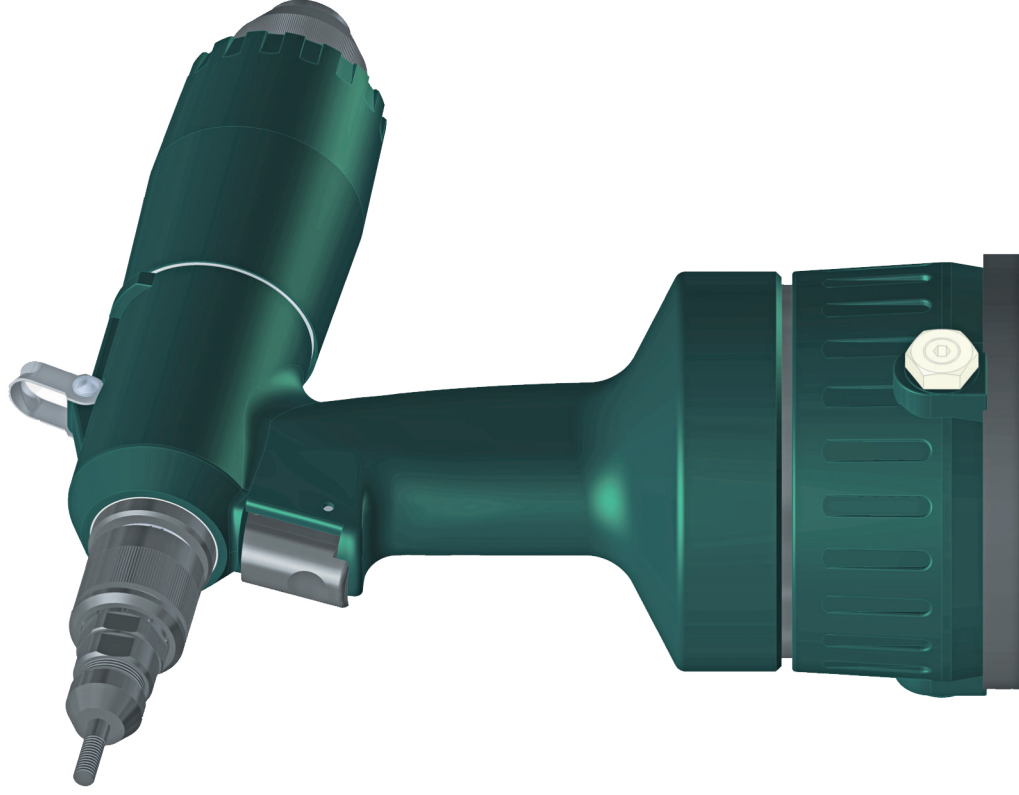

Automatic spin on without using a trigger – „Autospin“

Easy stroke adjustment



### Stroke adjustment on nose

- 1/10 of turn of knurled nut (1 click) adjusts stroke for 0.1 mm plus or minus according to direction of rotation (follow arrows + or -)
- 1 full turn of knurled nut increase of decrease stroke for 1 mm
- It's possible to adjust stroke only when compressed air is connect to the tool and trigger fully pressed – hydraulic cylinder is in back position.



#### NOTE:

- When adjusting without connected compressed air and pushed trigger in may result in serious damage of the equipment.
- When using easy stroke adjustment equipment on standard RL 50 it is not allowed to use stroke adjustment on valve body. Standard stroke adjustment on valve body must be set on maximum stroke.

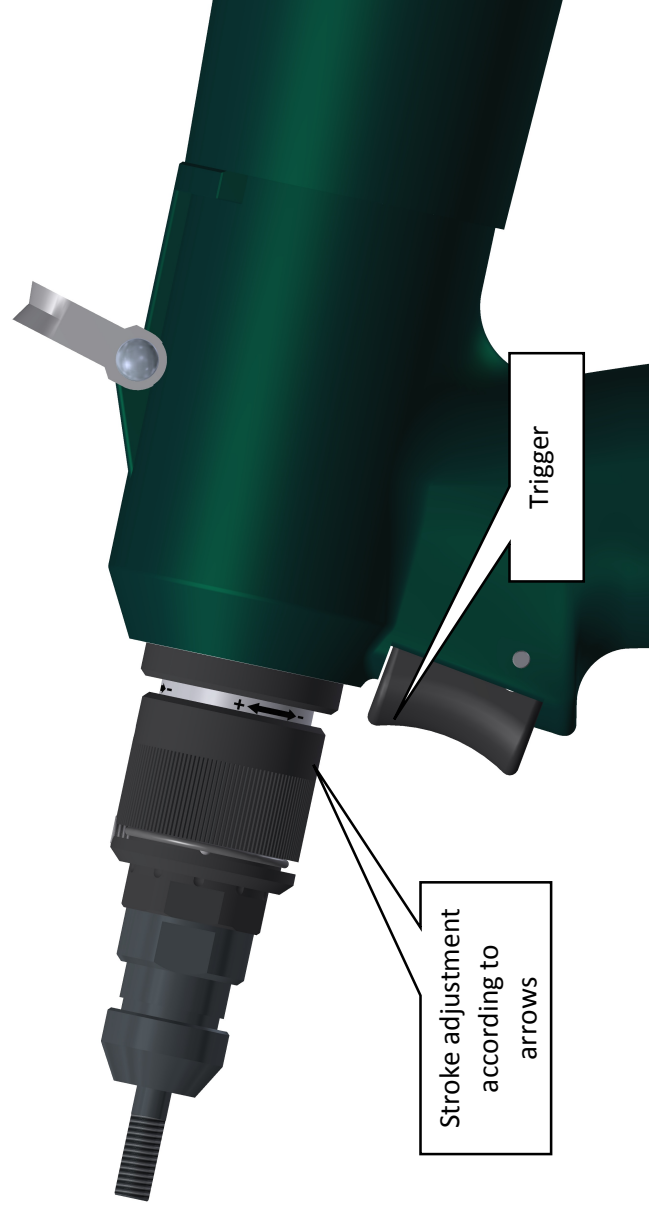

#### Spare parts kits:

87-0497 – Stroke adjustment kit

## Automatic spin on – „Autospin“

When pushing the mandrel it automatically switches on right spin and spins on a rivet.  
It's also possible to activate right spinning by pushing the trigger.



**NOTE:** when using stroke smaller than 2.5 mm, it's necessary to release screw on engine cover.

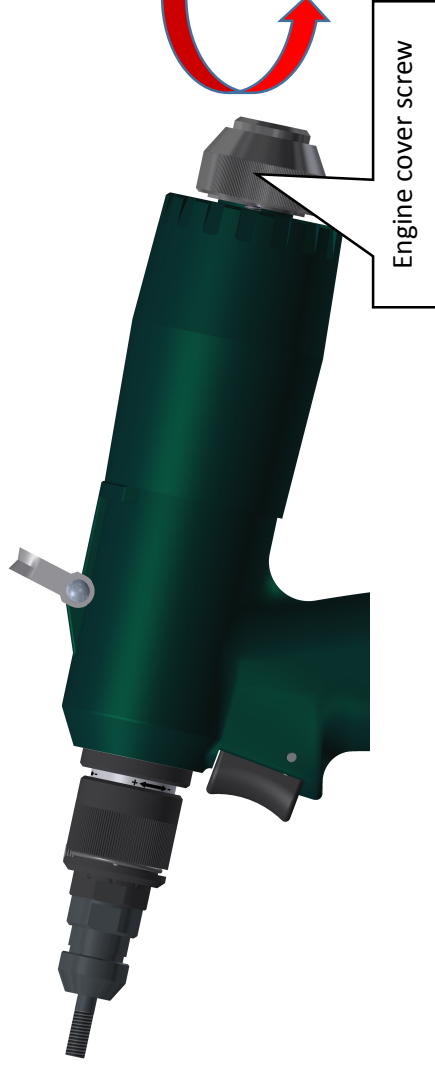

Spare parts kits: new parts compared to RL 50

New parts	
RL 50	RL 50A / AS
87-0166	87-0490
87-0354	87-0491
87-0346	87-0492
87-0348	87-0493
87-0372	87-0494

## Guarantee

Other than the official guarantee (6 months), the company RIVETEC also offers a guarantee of an additional 6 months from the date of purchase. (The bill being the proof thereof).

The following working parts are excluded from the guarantee agreement:

- Mandrel (4)
- Internal-thread mandrel (3)
- Nose piece (1)
- Socket head screw (7) with O-ring (8)

## Package Contents

- 1x Riveting Tool RL 50 / A / S / AS
- 1x Swivel Joint
- 1x Oil Gun
- 1x Adapter Screw
- 1x Internal Hex Key SW4
- 1x Mandrel M4 (is located in the package)
- 1x Mandrel M5 (is located in the package)
- 1x Mandrel M6 (mounted on the riveting tool)
- 1x Mandrel M8 (is located in the package)
- 1x Mandrel M10 (is located in the package)
- 1x Nose Piece M4 (is located in the package)
- 1x Nose Piece M5 (is located in the package)
- 1x Nose Piece M6 (mounted on the riveting tool)
- 1x Nose Piece M8 (is located in the package)
- 1x Nose Piece M10 (is located in the package)

## ES PROHLÁŠENÍ O SHODĚ EU DECLARATION OF CONFORMITY

Název produktu:  
Product Name:

**RL 50 / A / S / AS**

Kat. číslo:

**99 - 0024 / A / S / AS**

Cat. Number:

Určení produktu:  
Specifications:

pneumaticko-hydraulické nýtovací nářadí pro usazování maticových nýtů  
air-hydraulic riveting tool for installing threaded rivets

Výrobce

Manufacturer

RIVETEC s.r.o.

Albrechtice nad Vltavou 16

CZ-39816 Albrechtice nad Vltavou

IČ 60647761

**prohlašuje, že uvedený výrobek byl vyroben  
v souladu s požadavky následujících směrnic:**

**declares that the product was manufactured  
in conformity with the requirements of the following  
EC Directive:**

ČSN EN ISO 12100 Bezpečnost strojních zařízení

ČSN EN 349 Bezpečnost strojních zařízení – Nejmenší mezery k zamezení sřtačených částí lidského těla

ČSN EN 953 Bezpečnost strojních zařízení – Ochranné kryty

ČSN CR 954-100 Bezpečnost strojních zařízení: části řídicích systémů

ČSN EN 983 Bezpečnost strojních zařízení – Bezpečnostní požadavky pro fluidní zařízení a jejich součásti – Pneumatika

ČSN EN 999 Bezpečnost strojních zařízení – Umístění ochranných zařízení s ohledem na rychlosti přiblížení částí lidského těla

ČSN EN 61000-6-1 ed. 2 Elektromagnetická kompatibilita – Odolnost

ČSN EN 61000-6-4 ed. 2 Elektromagnetická kompatibilita – Emise

ČSN EN 60204-1 Bezpečnost strojních zařízení – Elektrické zařízení strojů – Všeobecné požadavky

ČSN EN ISO 13850 Bezpečnost strojních zařízení – Nouzové zastavení – Zásady pro konstrukci

ČSN EN ISO 13857 Bezpečnost strojních zařízení – Bezpečné vzdálenosti k zamezení dosahu k nebezpečným místům horními a dolními končetinami

ČSN EN ISO 1037 Bezpečnost strojních zařízení – Zamezení neočekávanému spuštění

ČSN EN 614-1 Bezpečnost strojních zařízení – Ergonomické zásady navrhování – Část 1

ČSN EN 60439-1 ed. 2 Rozvaděče nn – Část 1

2006/95/ES Elektrická zařízení určená pro používání v určitých mezích napětí

2004/108/ES Elektromagnetická kompatibilita

2006/42/ES Směrnice o strojích a zařízeních

Zákon č. 22/1997 Sb. o technických požadavcích

Zákon č. 71/2000 Sb. (změna zákona č. 22/1997 Sb.)

Zákon č. 205/2002 Sb. (změna zákona č. 22/1997 Sb.)

Zákon č. 226/2003 Sb. (změna zákona č. 22/1997 Sb.)

Zákon č. 102/2001 Sb. o obecné bezpečnosti výrobků

Zákon č. 227/2003 Sb. (změna zákona č. 102/2001 Sb.)

Narizení vlády č. 18/2003 Sb. o požadavcích na výrobky z hlediska jejich elektrické kompatibility

Narizení vlády č. 204/2003 Sb. o technických požadavcích na strojní zařízení

Místo a datum:  
Place and date:

Albrechtice nad Vltavou  
27.11.2015

Jméno, funkce a podpis autorizované osoby:  
Name, Title and Signature of Authorized Person:

Ing. Antonín Solfroň  
Managing Director





**RIVETEC s.r.o.**

Albrechtice nad Vltavou 16  
CZ - 398 16

Plant  
U Vodárny 1506 / 1 B22  
397 01 Písek

Tel.: +420 382 206 711  
Fax: +420 382 206 719  
E-Mail: [info@rivetec.cz](mailto:info@rivetec.cz)  
Web: [www.rivetec.cz](http://www.rivetec.cz)



**GEBR. TITGEMEYER GmbH & Co. KG**

Hannoversche Straße 97  
49084 Osnabrück

Tel. +49 541 5822-0  
Fax +49 541 5822-491

E-Mail: [vertrieb-gfb@titgemeyer.com](mailto:vertrieb-gfb@titgemeyer.com) .  
Web: [www.titgemeyer.com](http://www.titgemeyer.com)